

## Introduction

### ► Feature

Line pull: 8,181 kg / 18,000 lb wire rope first layer

Wire rope: 12.7 mm × 25 m (1/2" × 82') 6 × 29 - IWRC

Brake: Patented cone brake holds full load

Clutch: Turn the T-handle for rapid wire rope payout

Control: Handheld pendant switch powers the winch

### ► Unpacking

- Winch assembly..... 1 pc
- Detachable control box..... 1 pc
- Remote control..... 1 pc
- Wire rope with clevis hook..... 1 pc
- Roller fairlead..... 1 pc
- 1.8 m ( 6' ) 2 gauge battery lead..... 1 pc

### ► Read this manual carefully

You should carefully read and understand this manual before operating it. Careless winch operation may result in personal injury hazards or property damage.

## Installation

Before using the winch, make sure all electrical components have no corrosion or damaged; the environment should be clear and dry.

### ► Winch and roller fairlead mountings

- It is very important that the winch will be mounted on a flat and hard surface of mounting channel in order to make sure the motor, drum and gearbox housing are aligned correctly.
- Roller Fairlead does not mount to the winch directly.

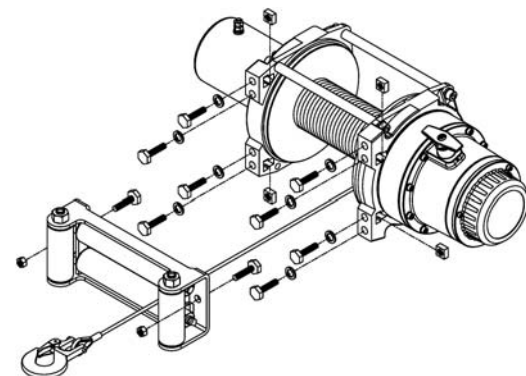

- The wire rope shall be wound in an under-wound orientation only.
- Eight (8) M12 x 1.75 pitch 8.8 grade high tensile steel bolts must be used in order to sustain the loads imposed on the winch mounting.
- Two (2) M12 x 1.75 pitch 8.8 grade high tensile steel bolts must be used for fastening the roller fairlead into the mounting channel.

## ► Wiring Diagram

Attach the black lead firmly to the negative (-) battery terminal and red lead to the positive (+) battery terminal. The voltage drop for the winch motor must not exceed 10% of the nominal voltage of 24V DC.

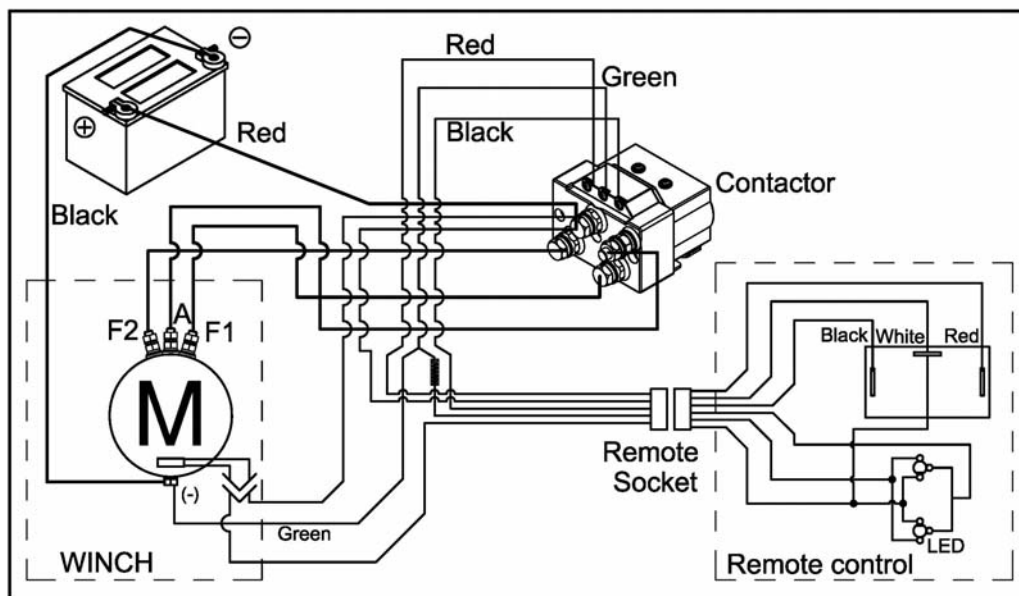

## ► Nut fastening for motor & contactor

1. Holding the lower nut on the stub and fastening the upper nut clockwise.
2. The torque setting for nut is 14 N-m/124 lb-in.

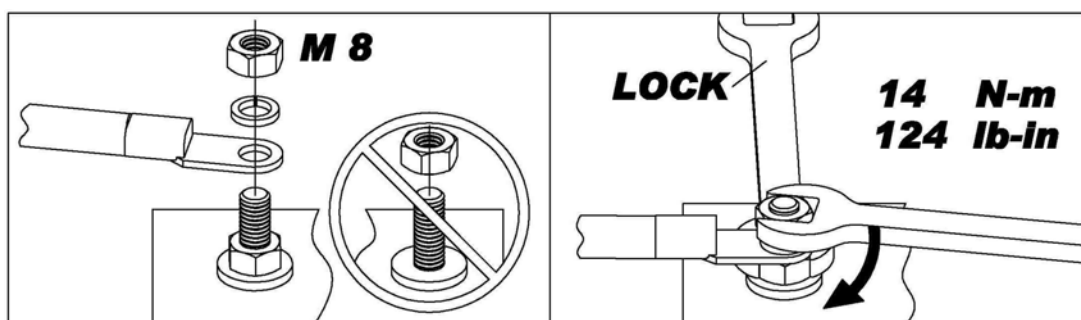

## Warning

- The winch is not intended to be used in any manner for the movement or lifting of personnel.
- The rated line pull shown is based on the first layer of rope on the drum.
- The rope winding on the drum shall remain 5 wraps from the drum.

## Parts List

Item No.	Description	Part No.	Qty
1	Motor 24V	881927	1
2	Tie bar kit	880045	3
3	Motor support rack	880046	1
4	Motor coupling	880047	1
5	Drum bushing	880048	2
6	Drum kit	881928	1
7	Gearbox support rack	880050	1
8	Grounding lead	880009	1
9	Wire rope	881929	1
10	1 <sup>st</sup> shaft	881930	1
11	3 <sup>rd</sup> ring gear kit	880054	1
12	3 <sup>rd</sup> stage carrier	881944	1
13	2 <sup>nd</sup> stage carrier	881943	1
14	1 <sup>st</sup> stage carrier	880107	1
15	Retaining ring	880058	1
16	1 <sup>st</sup> & 2 <sup>nd</sup> ring gear	880059	1
17	1 <sup>st</sup> pinion	880060	1
18	Clutch kit	880061	1
19	Gear box kit	880062	1
20	Brake base	880063	1
21	Cone brake disc kit	880021	1
22	Brake cover kit	880065	1
23	Roller fairlead	880066	1
24	Mounting hardware	880067	1
25	Remote control	880126	1
26	Handsaver strap	880026	1
27	Control box 24V	881165	1
27-1	Remote socket kit 24V	881374	1
27-2	Control pack 24V	881401	1
28	Brake clutch base	881434	1
29	Clevis hook	881996	1
30	Clamp	882160	2

# Winch Assembly

