

Introduction

► Feature

- Line pull: 9,072 kg / 20,000 lb wire rope first layer
- Wire rope: 12.7 mm × 25 m (1/2"×82') 6 × 29 - IWRC
- Brake: Patented cone brake holds full load
- Clutch: Turn the T-handle for rapid wire rope payout
- Control: Handheld pendant switch powers the winch



► Unpacking

- Winch assembly..... 1 pc
- Potted contro box..... 1 pc
- Remote control..... 1 pc
- Wire rope with hook..... 1 pc
- Roller fairlead..... 1 pc
- Cable Tensioner..... 1 pc
- 1.8 m (6') 2 gauge battery lead..... 1 pc

► Read this manual carefully

You should carefully read and understand this manual before operating it. Careless winch operation may result in personal injury hazards or property damage.

Installation

Before using the winch, make sure all electrical components have no corrosion or damaged; the environment should be clear and dry.

► Winch and roller fairlead mountings

- It is very important that the winch will be mounted on a flat and hard surface of mounting channel in order to make sure the motor, drum and gearbox housing are aligned correctly.
- Roller fairlead does not mount to the winch

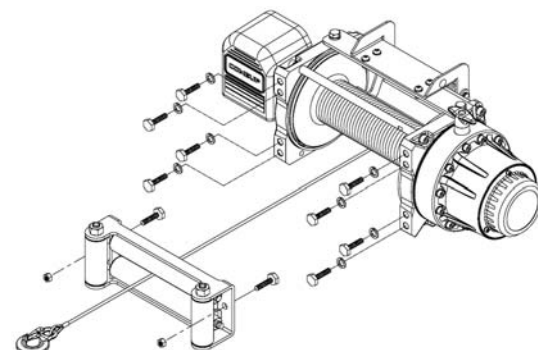

directly.

- The wire rope shall be wound in an under-wound orientation only.
- Eight (8) M12 x 1.75 pitch 8.8 grade w/76 N-m torque setting (maximum) high tensile steel bolts must be used in order to sustain the loads imposed on the winch mounting.
- Two (2) M12 x 1.75 pitch 8.8 grade w/76 N-m torque setting (maximum) high tensile steel bolts must be used for fastening the roller fairlead into the mounting channel.

► Wiring Diagram

Attach the black lead firmly to the negative (-) battery terminal and red lead to the positive (+) battery terminal. The voltage drop for the winch motor must not exceed 10% of the nominal voltage of 24V DC.

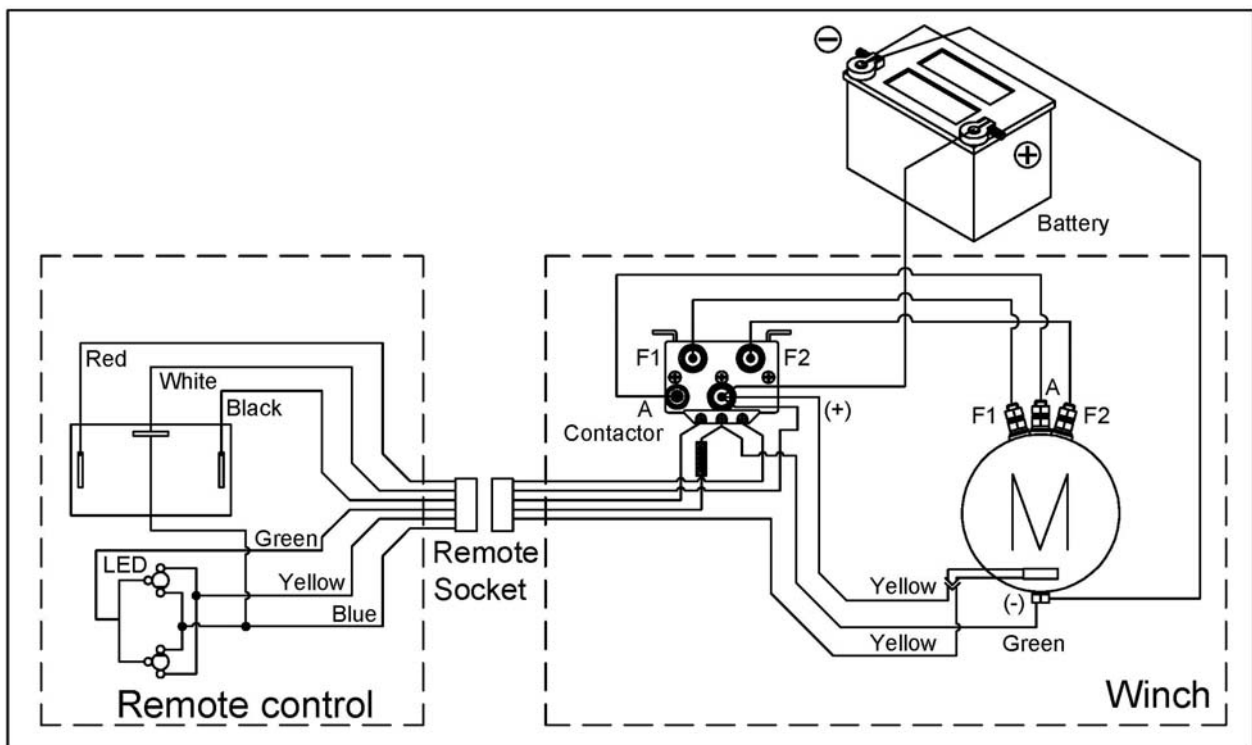

► Nut fastening for motor & contactor

1. Holding the lower nut on the stub and fastening the upper nut clockwise.
2. The torque setting for nut is 14 N-m/124 lb-in.

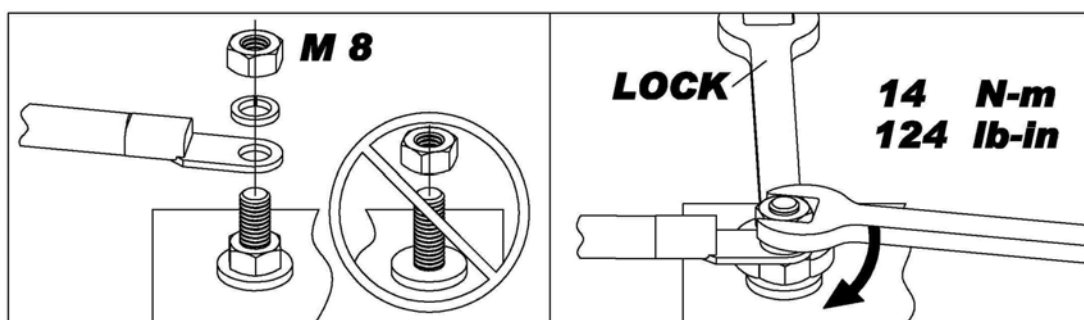

Warning

- The winch is not intended to be used in any manner for the movement or lifting of personnel.
- The rated line pull shown is based on the first layer of rope on the drum.
- The rope winding on the drum shall remain 5 wraps from the drum.

Parts List

Item No.	Description	Part No.	Qty
1	Waterproof motor w/control box	882199	1
2	Tie bar kit	882200	3
3	Motor coupling	882201	1
4	Drum bushing	880048	1
5	Drum kit	882203	1
6	Drum bushing	882204	1
7	Gearbox support rack	882205	1
8	Grounding lead	880009	1
9	Wire rope	881929	1
10	Clevis hook	881996	1
11	1 st shaft	882207	1
12	3 rd ring gear kit	882208	1
13	3 rd stage carrier	882210	1
14	2 nd stage carrier	882211	1
15	1 st stage carrier	882212	1
16	1 st pinion	882213	1
17	Clutch kit	882214	1
18	Gear box kit	882215	1
19	Cone brake disc kit	882216	1
20	Brake clutch base	882217	1
21	Brake cover kit	882423	1
22	Roller fairlead	882218	1
23	Cable tensioner	882219	1
24	Mounting hardware	882371	1
25	Remote control	881671	1
26	Handsaver strap	880026	1

Winch Assembly

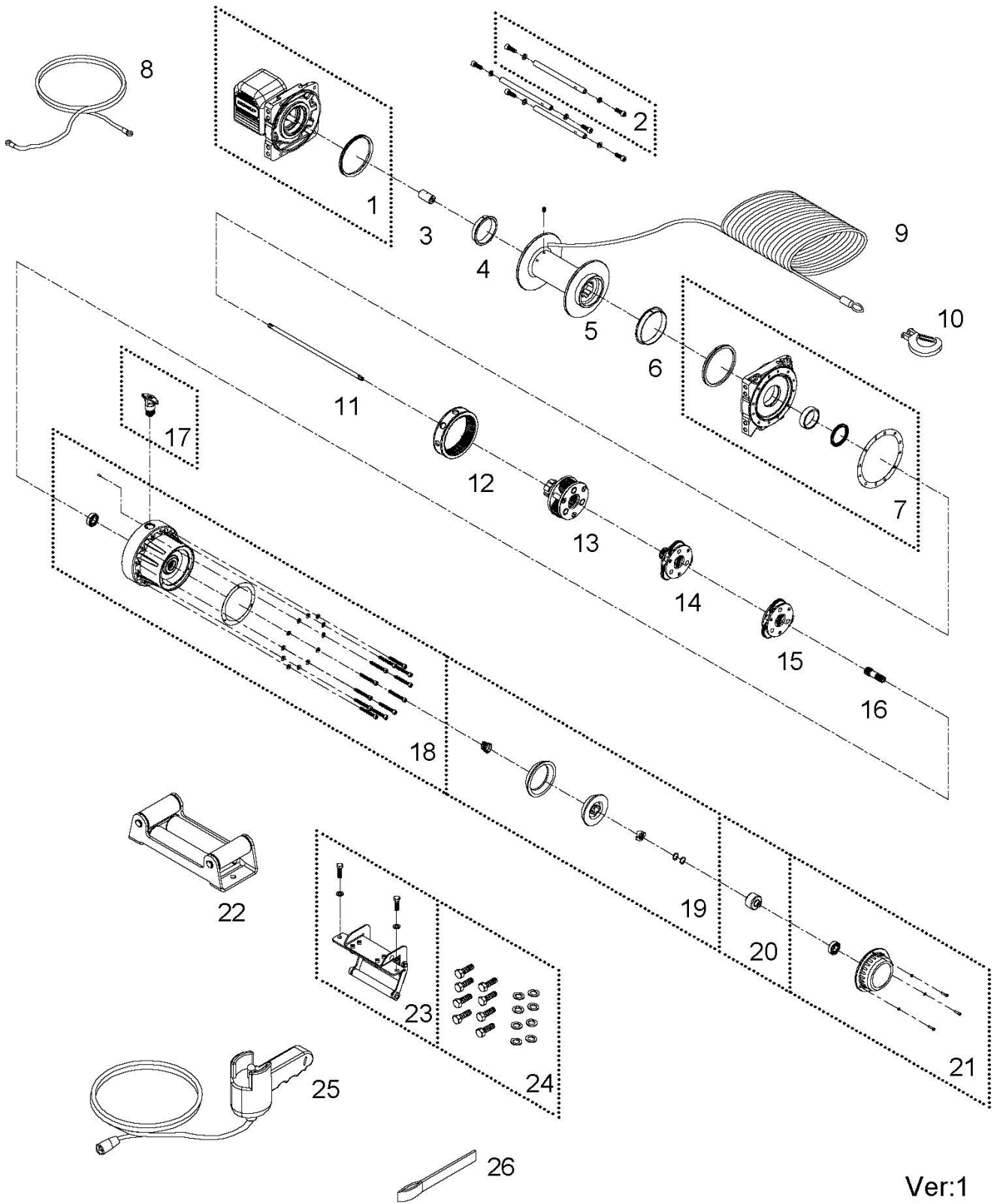

Ver:1